

POSTER PRESENTATION INFORMATION AND GUIDELINES

Air Quality VII: An International Conference on Carbon Management, Mercury, Trace Substances, SO_x, NO_x, and Particulate Matter
Crystal Gateway Marriott Hotel – Arlington, Virginia
October 26–29, 2009

Goal of Poster Presentations

Poster presentations have become a popular form of communication. Ideally, an effective poster presentation provokes lively, informal, one-on-one, and in-depth discussions. This can be achieved by keeping in mind that not only should the material be interesting and contain technical information, but the visual presentation should be crisp, clean, and eye-catching. Remember that you will have a strolling audience, so an intriguing display will draw attention. Once the viewer has come to take a closer look at a display, all aspects of the design and the science work together to hold, or lose, the viewer's interest.

Poster Schedule

Setup: Presenters are responsible for setting up and taking down their presentations. The time for poster setup is on Tuesday, October 27, between 3:10 and 5:00 p.m. (setup begins during the break between technical sessions).

Session Time: **The poster session will be held on Tuesday, October 27, from 5:00 to 8:30 p.m. in conjunction with an exhibit social.** Poster presenters are required to be in attendance during this official poster session. The poster session will be held in the Arlington Ballroom, which is where the conference exhibit and breaks are held.

Takedown: **Posters may be dismantled following the poster session (after 8:30 p.m. on Tuesday, October 27).**

Board Information

- Each presenter will be preassigned a board 4' (121.92 cm) high H × 8' (243.84 cm) wide, mounted on black metal stands. The boards are covered with black fabric (see sketch on next page).
- Presenters must provide their own mounting supplies. The poster boards are fabric covered, and using velcro is recommended. Push pins are not recommended; however, T-pins work well. A chair will be available at each poster area.
- Presenter will receive a layout of the poster session with their poster location highlighted as part of their registration packet upon arrival at the conference.

Poster Content

Posters should consist of the following:

- Title
- Objective(s)
- Methods/Data/Analysis – Research Conducted
- Conclusions/Results

Layout and Design

- The viewer should see an easy-to-read title and a neat, uncluttered arrangement from 10–15 feet away. Posters should be labeled clearly so that it is obvious where to begin viewing the poster and where to proceed from

there (usually top to bottom, left to right). To accommodate the viewer, poster pieces should be numbered or have arrows leading from one piece to the next.

- All lettering should be legible from 5 feet away. The title lettering should be the largest. Text material should be very brief. Supporting text should be presented in brief segments with appropriate illustrations.
- If your presentation will require electricity, please contact Anne Fiala at (701) 777-3119 or afiala@undeerc.org.

General Information

- Poster presenters must register for the conference using the registration form, which can be found in the conference brochure or on the EERC Web site at www.undeerc.org/aq7.
- Poster presenters are invited and encouraged to submit a paper for inclusion in the conference preproceedings (optional). Enclosed are the paper guidelines; papers are due September 25, 2009. In addition, any poster papers submitted will be included in the CD-ROM Proceedings provided to participants following the conference. If you are not including a paper in the preproceedings, the abstract you submitted will be included in the preproceedings, and we ask that you please consider providing more detailed handouts of your material (3-hole punched) at the conference for interested viewers.

Questions

If you have any questions or need additional clarification of these guidelines, please contact Anne Fiala at (701) 777-3119 or afiala@undeerc.org.

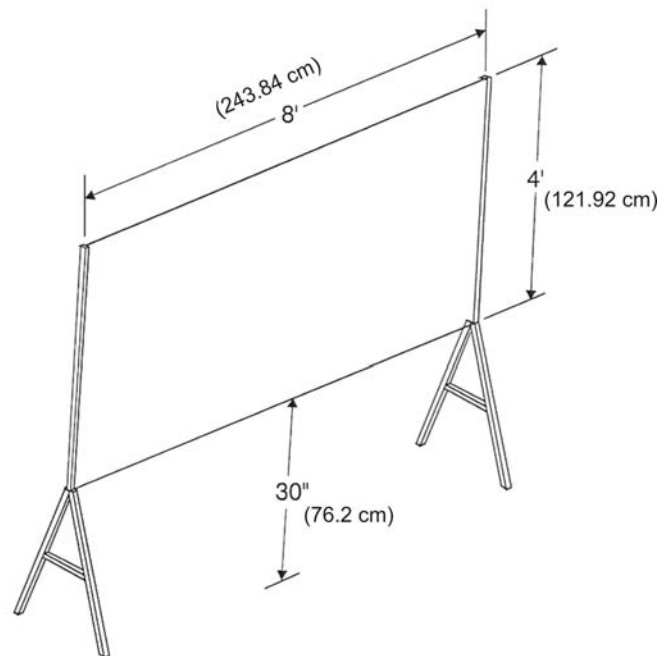

Poster Display Board Illustration